

Inorax-ST Server Cabinet



Inorax-ST Server Cabinet

A cost effective server rack cabinet system developed for independent use and Data Center environments. Inorax-ST server rack cabinet system is designed and engineered for demanding Data Center environments. It is designed to house all servers manufactured by major brands including HP, Dell, Sun, Cisco, Juniper, IBM, Compaq to name but a few. To achieve optimum versatility within the server rack, users can set multiple depths throughout the cabinet by adjustable 19" mounting rails mounted on heavy duty side supports. Horizontally divided side panels provide ease of access and convenient post-installation maintenance. Optional 80% perforations on front and rear doors enable optimum airflow within the rack cabinet. Optional cable tray channels can be fitted on top of the rack provides perfect cable routing eliminating the need for raised floor systems. Flat-pack option enables savings up to 60% in the transport cost and warehouse space

Technical Features

Material	1-1,2-1,5-2mm Steel
Color	RAL 7035 or RAL 9005
Compliance	RoHS, UL Certified
Packaging	Assembled or unassembled
Maximum Static Load	Up to 1500 kg.
Finish	Frame, doors, side panels, top and bottom covers. Electrostatic Powder Paint, 19" mounting rails; Zinc-plated

Standard Configuration

- Perforated front and rear doors, Free Air Ratio (FAR): %65
- Front & rear doors with swing handle Multi point-espagnolette
- Solid Side Panels with cylindrical locks and latches
- Internal top sheet with 3 cable entries for 800 width, 1 cable entry for 600 width racks and fan cut-outs
- 2 Pairs of depth adjustable heavy duty 19" Mounting Rails
- 2 Pairs of Adjustable Feet
- Bottom cover with 3 cable entries for 800 width, 1 cable entry for 600 width racks



CERTIFIED



Front View



Front View Open



3/4 View



Side View

Inorax-ST Server Cabinet

Technical Drawing

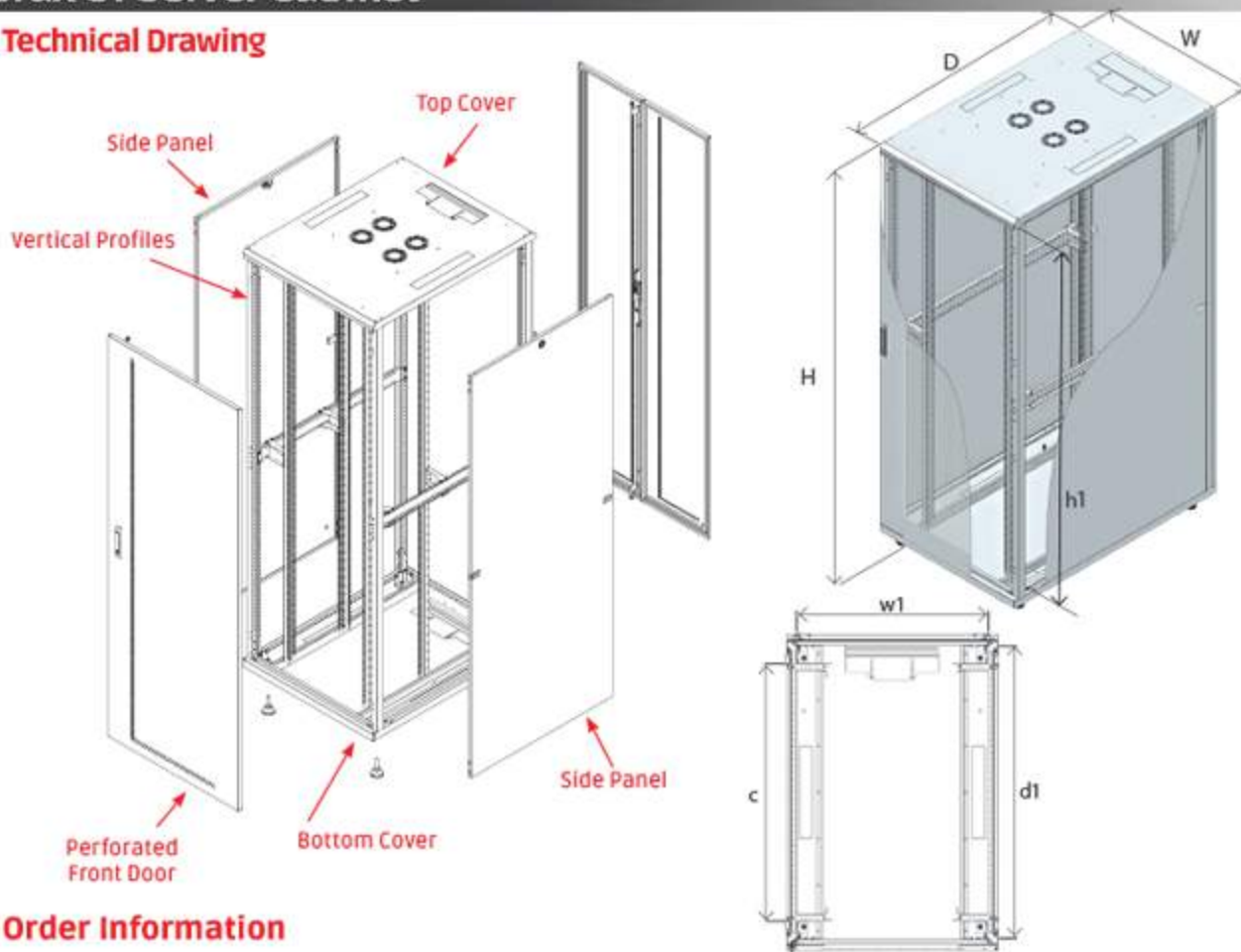

Order Information

Height U	Outer Width (w) mm	Outer Depth (D) mm	Outer Height (H) mm	Inner Width (w1) mm	Inner Depth (d1) mm	Inner Height (h1) mm	19" Rails Adjustable Depth Range (c)	Weight kg	Part No
26U	600	1000	1322	503	950	1162	123 - 773	84,0	CSS-X-2660A
26U	600	1200	1322	503	1150	1162	123 - 973	95,8	CSS-X-2662A
36U	600	1000	1766	503	950	1607	123 - 773	104,9	CSS-X-3660A
36U	600	1200	1766	503	1150	1607	123 - 973	116,5	CSS-X-3662A
39U	800	1000	1900	703	950	1740	123 - 773	130,2	CSS-X-3980A
42U	600	1000	2033	503	950	1873	123 - 773	117,2	CSS-X-4260A
42U	600	1100	2033	503	1050	1873	123 - 873	123,0	CSS-X-4261A
42U	600	1200	2033	503	1150	1873	123 - 973	129,0	CSS-X-4262A
42U	800	1000	2033	703	950	1873	123 - 773	136,9	CSS-X-4280A
42U	800	1100	2033	703	1050	1873	123 - 873	143,6	CSS-X-4281A
42U	800	1200	2033	703	1150	1873	123 - 973	150,5	CSS-X-4282A
42U	1000	1000	2033	903	950	1873	123 - 773	156,9	CSS-X-4211A
44U	600	1000	2122	903	950	1962	123 - 773	156,9	CSS-X-4461A
47U	600	1000	2255	503	950	2095	123 - 773	126,7	CSS-X-4760A
47U	600	1100	2255	503	1050	2095	123 - 873	133,0	CSS-X-4761A
47U	600	1200	2255	503	1150	2095	123 - 973	139,3	CSS-X-4762A
47U	800	1000	2255	703	950	2095	123 - 773	147,3	CSS-X-4780A
47U	800	1100	2255	703	1050	2095	123 - 873	154,5	CSS-X-4781A
47U	800	1200	2255	703	1150	2095	123 - 973	161,7	CSS-X-4782A

X (Color code): 7-RAL 7035 Light Grey, 9-RAL 9005 Black

Inorax-ST Network Cabinet

Components of Inorax-ST Rack Cabinets

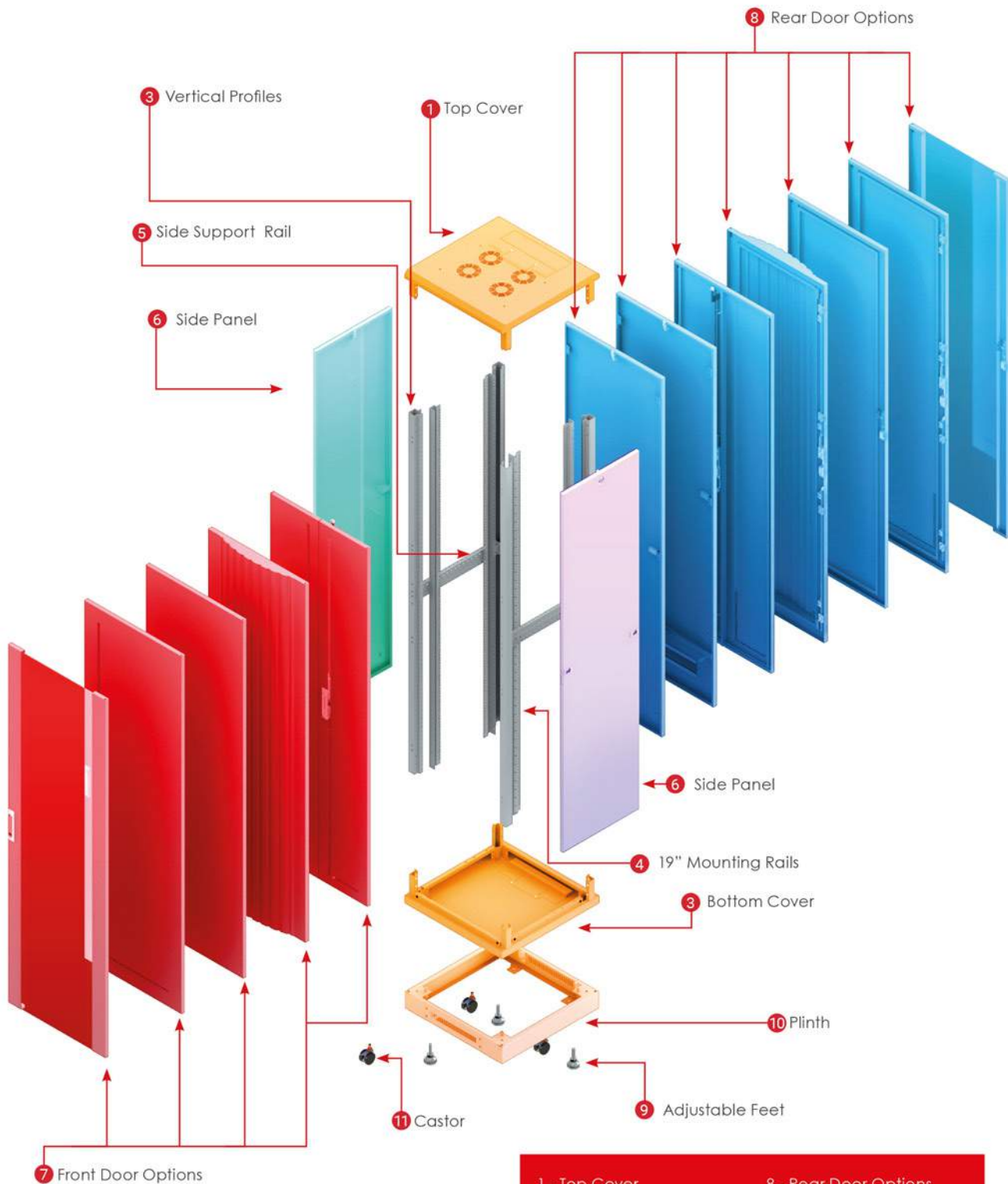

- | | |
|------------------------|-----------------------|
| 1 - Top Cover | 8 - Rear Door Options |
| 2 - Vertical Profiles | 9 - Adjustable Feet |
| 3 - Side Support Rail | 10 - Plinth |
| 4 - 19" Mounting Rails | 11 - Castor |
| 5 - Side Panel | |
| 6 - Front Door Options | |

Inorax-ST Network Cabinet



Page : 123-124



Page : 124-126



Page : 127-129



Page : 129-130



Page : 130-132

Inorax-ST Network Cabinet

Components of Inorax-ST Rack Cabinets

Top Cover

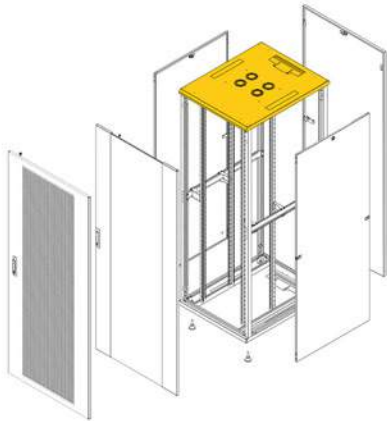
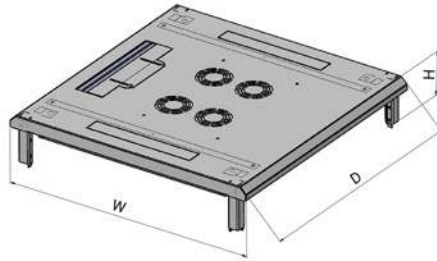

Component Position

Top Cover Options

Material	1.5 mm Steel	Finish	Electrostatic Powder Paint	
Color	RAL 7035 (Light Grey) and RAL 9005 (Black)			
W (mm)	D (mm)	H (mm)	Weight kg	Part No
600	600	154	10,8	CSZ-X-YY660-0401
600	800	154	12,7	CSZ-X-YY680-0401
600	1000	154	14,6	CSZ-X-YY600-0401
600	1100	154	15,5	CSZ-X-YY610-0401
600	1200	154	16,4	CSZ-X-YY620-0401
800	800	154	16,7	CSZ-X-YY880-0401
800	1000	154	19,6	CSZ-X-YY800-0401
800	1100	154	21,0	CSZ-X-YY810-0401
800	1200	154	22,4	CSZ-X-YY820-0401

Bottom Cover

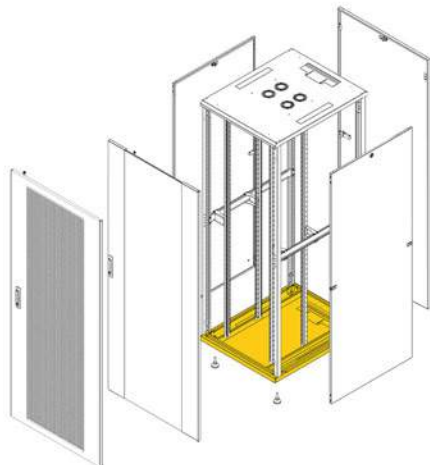
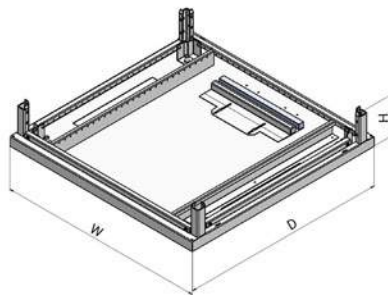

Component Position

Bottom Cover Options

Material	1.5 mm Steel	Finish	Electrostatic Powder Paint	
Color	RAL 7035 (Light Grey) and RAL 9005 (Black)			
W (mm)	D (mm)	H (mm)	Weight kg	Part No
600	600	154	11,1	CSZ-X-YY660-0403
600	800	154	13,0	CSZ-X-YY680-0403
600	1000	154	15,0	CSZ-X-YY600-0403
600	1100	154	15,9	CSZ-X-YY610-0403
600	1200	154	16,9	CSZ-X-YY620-0403
800	800	154	17,2	CSZ-X-YY880-0403
800	1000	154	20,0	CSZ-X-YY800-0403
800	1100	154	21,5	CSZ-X-YY810-0403
800	1200	154	22,9	CSZ-X-YY820-0403

X (Color code): 7:RAL 7035 Light Grey, 9:RAL 9005 Black

Inorax-ST Network Cabinet

Vertical Profiles

Vertical Profile Options

Material	1.5 mm Steel	Finish	Electrostatic Powder Paint		
Color	RAL 7035 (Light Grey) and RAL 9005 (Black)				
H (U)	W (mm)	D (mm)	H (mm)	Weight kg	Part No
16U	48,5	57	754	1,4	CSZ-X-16YY0-0300
22U	48,5	57	1021	1,8	CSZ-X-22YY0-0300
26U	48,5	57	1199	2,2	CSZ-X-26YY0-0300
32U	48,5	57	1465	2,6	CSZ-X-32YY0-0300
36U	48,5	57	1643	2,9	CSZ-X-36YY0-0300
39U	48,5	57	1777	3,2	CSZ-X-39YY0-0300
42U	48,5	57	1910	3,5	CSZ-X-42YY0-0300
47U	48,5	57	2132	3,8	CSZ-X-47YY0-0300

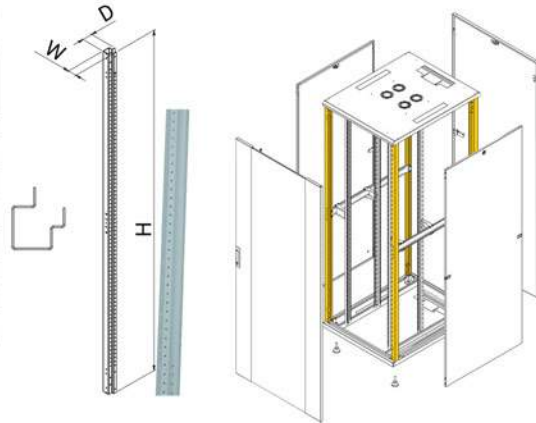

Component Position

19" Mounting Rail Options

Material	2 mm Steel	Finish	Zinc-Plated		
H (U)	W (mm)	D (mm)	H (mm)	Weight kg	Part No
16U	33	52	753	1,0	CSZ-0-16YY0-0600
22U	33	52	1020	1,3	CSZ-0-22YY0-0600
26U	33	52	1198	1,5	CSZ-0-26YY0-0600
32U	33	52	1464	1,8	CSZ-0-32YY0-0600
36U	33	52	1642	2,0	CSZ-0-36YY0-0600
39U	33	52	1776	2,2	CSZ-0-39YY0-0600
42U	33	52	1909	2,4	CSZ-0-42YY0-0600
47U	33	52	2131	2,7	CSZ-0-47YY0-0600

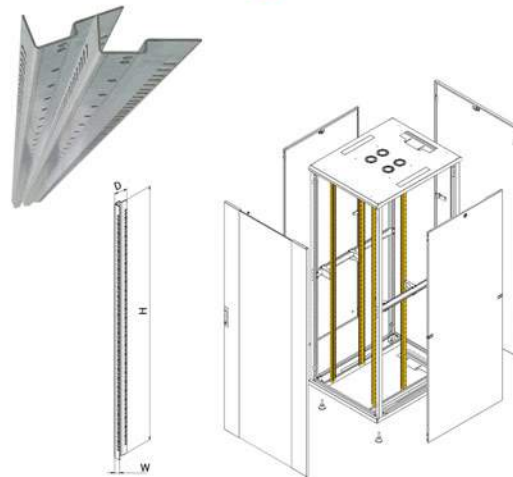

Component Position

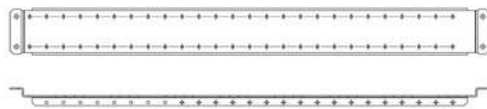

Side Support Rails

Side Support Rail Options

Material	2 mm Steel	Finish	Zinc-Plated
Cabinet W (mm)	Cabinet D (mm)	Weight kg	Part No
600	600	0,7	CSZ-0-YY660-0700
600	800	0,8	CSZ-0-YY680-0700
600	1000	0,8	CSZ-0-YY600-0700
600	1100	0,9	CSZ-0-YY610-0700
600	1200	0,9	CSZ-0-YY620-0700
800	800	0,8	CSZ-0-YY880-0700
800	1000	0,9	CSZ-0-YY800-0700
800	1100	1,0	CSZ-0-YY810-0700
800	1200	1,0	CSZ-0-YY820-0700

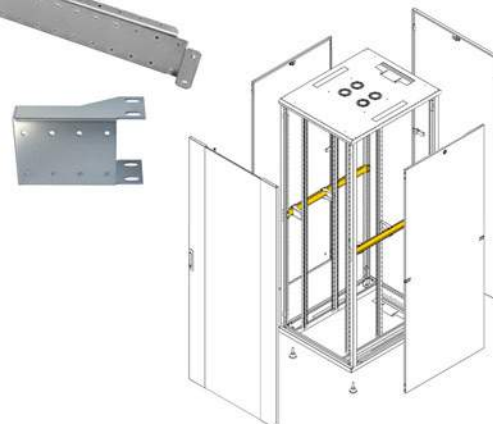

Component Position

X (Color code): 7:RAL 7035 Light Grey, 9:RAL 9005 Black

Inorax-ST Network Cabinet

Side Panel

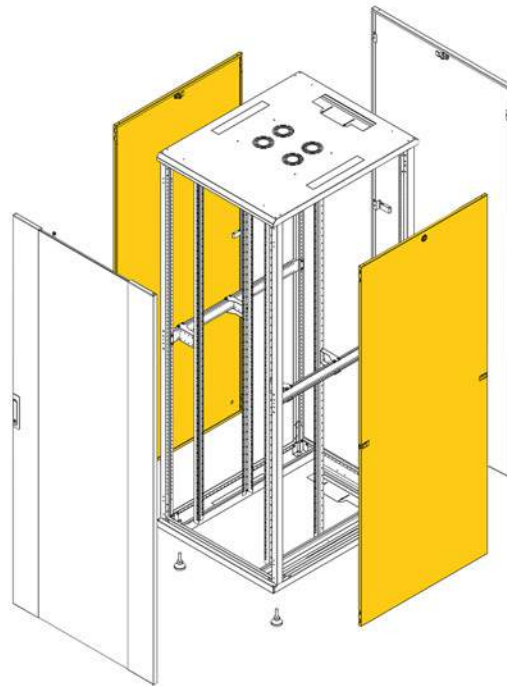
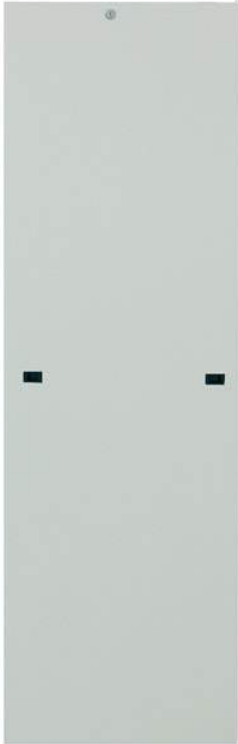

Component Position

Side Panel Options

Material	1 mm Steel	Finish	Electrostatic Powder Paint
Color	RAL 7035 (Light Grey) and RAL 9005 (Black)		

H (U)	W (mm)	D (mm)	H (mm)	Part No
16U	600	22	749	CSZ-X-16Y60-0501
22U	600	22	1016	CSZ-X-22Y60-0501
22U	800	22	1016	CSZ-X-22Y80-0501
26U	600	22	1194	CSZ-X-26Y60-0501
26U	800	22	1194	CSZ-X-26Y80-0501
26U	1000	22	1194	CSZ-X-26Y00-0501
32U	600	22	1460	CSZ-X-32Y60-0501
32U	800	22	1460	CSZ-X-32Y80-0501
36U	600	22	1638	CSZ-X-36Y60-0501
36U	800	22	1638	CSZ-X-36Y80-0501
36U	1000	22	1638	CSZ-X-36Y00-0501
36U	1200	22	1638	CSZ-X-36Y20-0501
39U	800	22	1772	CSZ-X-39Y80-0501
39U	1000	22	1772	CSZ-X-39Y00-0501
42U	600	22	1905	CSZ-X-42Y60-0501
42U	800	22	1905	CSZ-X-42Y80-0501
42U	1000	22	1905	CSZ-X-42Y00-0501
42U	1100	22	1905	CSZ-X-42Y10-0501
42U	1200	22	1905	CSZ-X-42Y20-0501
47U	600	22	2127	CSZ-X-47Y60-0501
47U	800	22	2127	CSZ-X-47Y80-0501
47U	1000	22	2127	CSZ-X-47Y00-0501
47U	1100	22	2127	CSZ-X-47Y10-0501
47U	1200	22	2127	CSZ-X-47Y20-0501

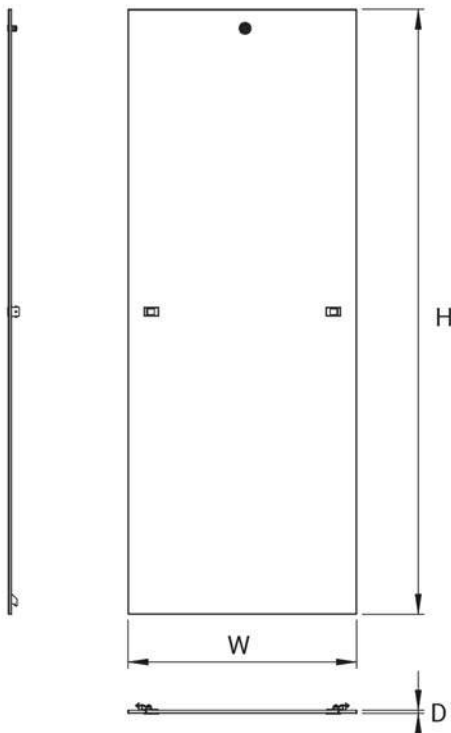

X (Color code): 7:RAL 7035 Light Grey, 9:RAL 9005 Black

Inorax-ST Network Cabinet

Rear Metal Solid Panel

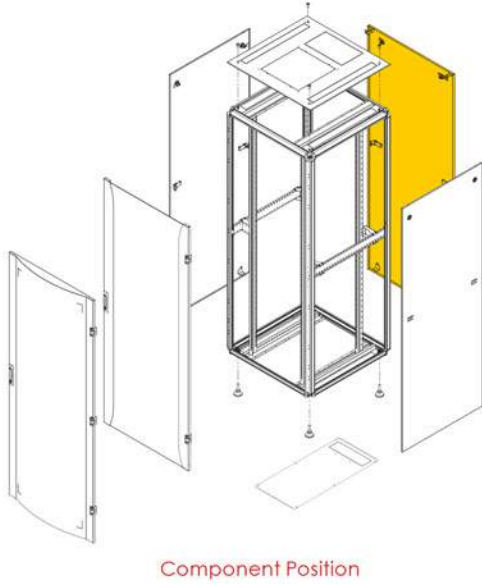

Rear Metal Solid Panel Options

Material	1 mm Steel		Finish	Zinc-Plated		
H (U)	W (mm)	D (mm)	H (mm)	Weight kg	Part No	
16U	600	23	752	5,1	CSZ-X-166Y0-0901	
22U	600	23	1018	6,7	CSZ-X-226Y0-0901	
22U	800	23	1018	8,8	CSZ-X-228Y0-0901	
26U	600	23	1196	7,8	CSZ-X-266Y0-0901	
26U	800	23	1196	10,2	CSZ-X-268Y0-0901	
32U	600	23	1463	9,5	CSZ-X-326Y0-0901	
32U	800	23	1463	12,3	CSZ-X-328Y0-0901	
36U	600	23	1641	10,6	CSZ-X-366Y0-0901	
36U	800	23	1641	13,8	CSZ-X-368Y0-0901	
39U	800	23	1774	14,9	CSZ-X-398Y0-0901	
42U	600	23	1907	12,2	CSZ-X-426Y0-0901	
42U	800	23	1907	16,0	CSZ-X-428Y0-0901	
47U	600	23	2130	13,6	CSZ-X-476Y0-0901	
47U	800	23	2130	17,7	CSZ-X-478Y0-0901	

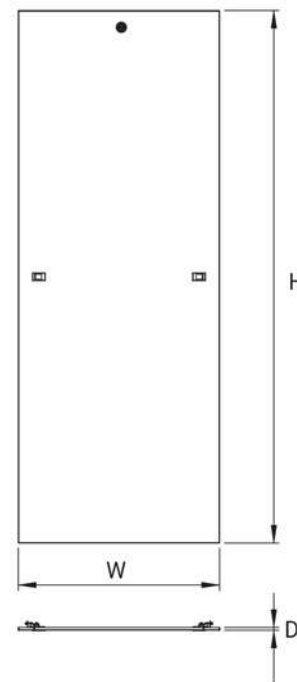

X (Color code): 7:RAL 7035 Light Grey, 9:RAL 9005 Black

Inorax-ST Network Cabinet

Single Door Options Metal Solid Door

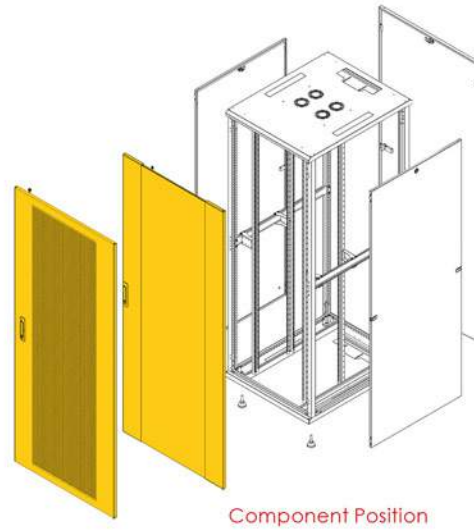
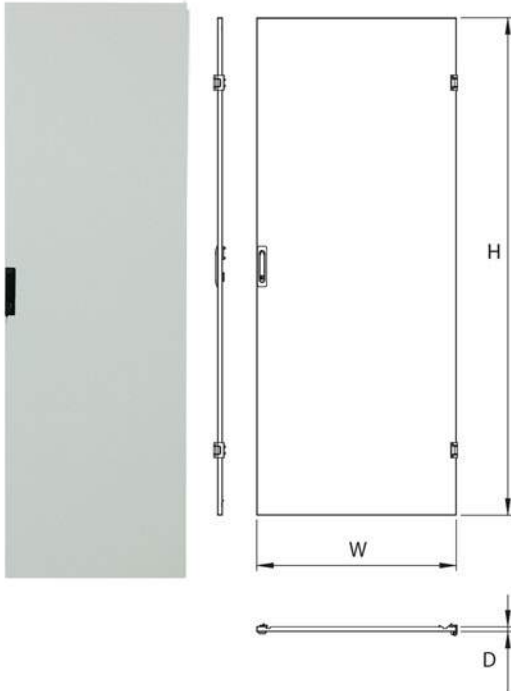

Metal Solid Door Options

Material	1.2 mm Steel	Finish	Electrostatic Powder Paint
Color	RAL 7035 (Light Grey) and RAL 9005 (Black)		

H (U)	W (mm)	D (mm)	H (mm)	Weight kg	Part No
16U	600	22	749	6,87	CSZ-X-166Y0-0902
22U	600	22	1016	8,94	CSZ-X-226Y0-0902
22U	800	22	1016	11,26	CSZ-X-228Y0-0902
26U	600	22	1194	10,32	CSZ-X-266Y0-0902
26U	800	22	1194	12,97	CSZ-X-268Y0-0902
32U	600	22	1460	12,39	CSZ-X-326Y0-0902
32U	800	22	1460	15,54	CSZ-X-328Y0-0902
36U	600	22	1638	13,77	CSZ-X-366Y0-0902
36U	800	22	1638	17,26	CSZ-X-368Y0-0902
39U	800	22	1772	18,54	CSZ-X-398Y0-0902
42U	600	22	1905	15,84	CSZ-X-426Y0-0902
42U	800	22	1905	19,83	CSZ-X-428Y0-0902
47U	600	22	2127	17,56	CSZ-X-476Y0-0902
47U	800	22	2127	21,97	CSZ-X-478Y0-0902

Glass Door

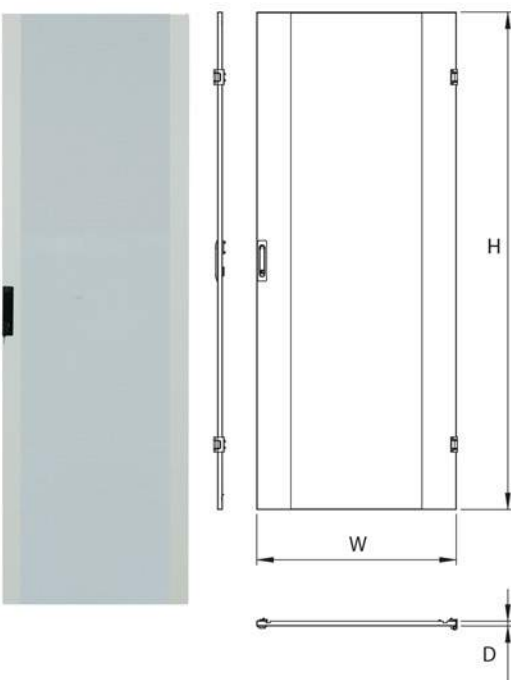

Glass Door Options

Material	1.2 mm Steel	Finish	Electrostatic Powder Paint
Color	RAL 7035 (Light Grey) and RAL 9005 (Black)		

H (U)	W (mm)	D (mm)	H (mm)	Weight kg	Part No
16U	600	22	749	5,53	CSZ-X-166Y0-0903
22U	600	22	1016	7,42	CSZ-X-226Y0-0903
22U	800	22	1016	9,77	CSZ-X-228Y0-0903
26U	600	22	1194	8,68	CSZ-X-266Y0-0903
26U	800	22	1194	11,42	CSZ-X-268Y0-0903
32U	600	22	1460	10,56	CSZ-X-326Y0-0903
32U	800	22	1460	13,9	CSZ-X-328Y0-0903
36U	600	22	1638	11,82	CSZ-X-366Y0-0903
36U	800	22	1638	15,55	CSZ-X-368Y0-0903
39U	800	22	1772	16,79	CSZ-X-398Y0-0903
42U	600	22	1905	13,7	CSZ-X-426Y0-0903
42U	800	22	1905	18,02	CSZ-X-428Y0-0903
47U	600	22	2127	15,27	CSZ-X-476Y0-0903
47U	800	22	2127	20,09	CSZ-X-478Y0-0903

X (Color code): 7:RAL 7035 Light Grey, 9:RAL 9005 Black

Inorax-ST Network Cabinet

Perforated Flat Door

Perforated Flat Door Options

Material	1.2 mm Steel	Color	RAL 7035 (Light Grey) and RAL 9005 (Black)		
Finish	Electrostatic Powder Paint	Perforation Rate	65%		
H (U)	W (mm)	D (mm)	H (mm)	Weight kg	Part No
26U	600	22	1194	7,81	CSZ-X-266Y0-0904
36U	600	22	1638	10,15	CSZ-X-366Y0-0904
39U	800	22	1772	14,02	CSZ-X-398Y0-0904
42U	600	22	1905	11,80	CSZ-X-426Y0-0904
42U	800	22	1905	15,17	CSZ-X-428Y0-0904
47U	600	22	2127	12,97	CSZ-X-476Y0-0904
47U	800	22	2127	16,69	CSZ-X-478Y0-0904

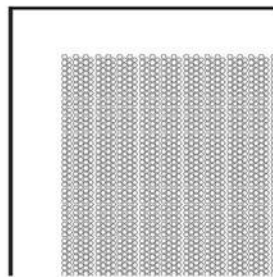

Perforation Detail

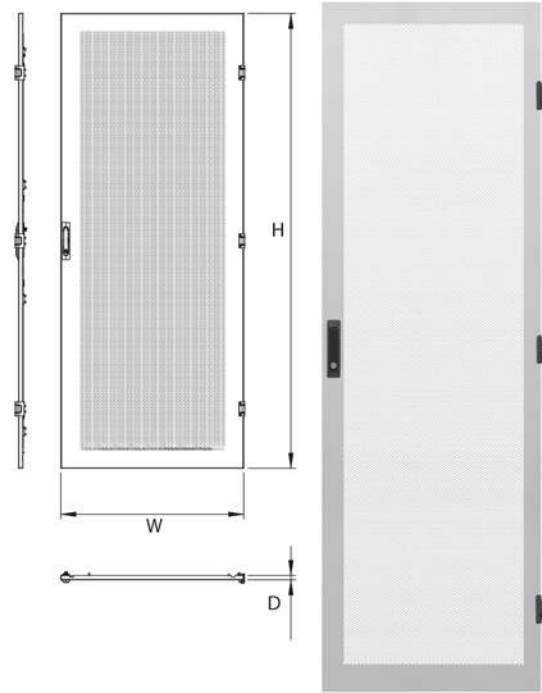

High Perforation Rated Flat Door Options

Material	1.2 mm Steel	Color	RAL 7035 (Light Grey) and RAL 9005 (Black)		
Finish	Electrostatic Powder Paint	Perforation Rate	80%		
H (U)	W (mm)	D (mm)	H (mm)	Weight kg	Part No
26U	600	22	1194	7,51	CSZ-X-266Y0-0909
36U	600	22	1638	9,85	CSZ-X-366Y0-0909
39U	800	22	1772	13,72	CSZ-X-398Y0-0909
42U	600	22	1905	11,50	CSZ-X-426Y0-0909
42U	800	22	1905	14,87	CSZ-X-428Y0-0909
47U	600	22	2127	12,67	CSZ-X-476Y0-0909
47U	800	22	2127	16,39	CSZ-X-478Y0-0909

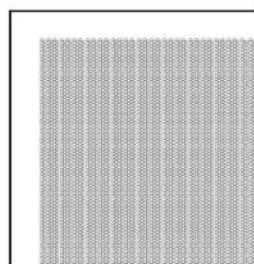

Perforation Detail

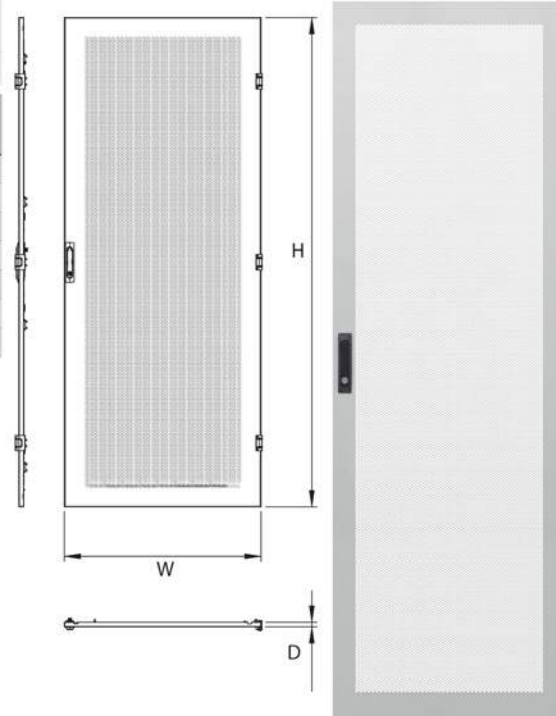

X (Color code): 7:RAL 7035 Light Grey, 9:RAL 9005 Black

Inorax-ST Network Cabinet

Double Door Options Double Perforated Door

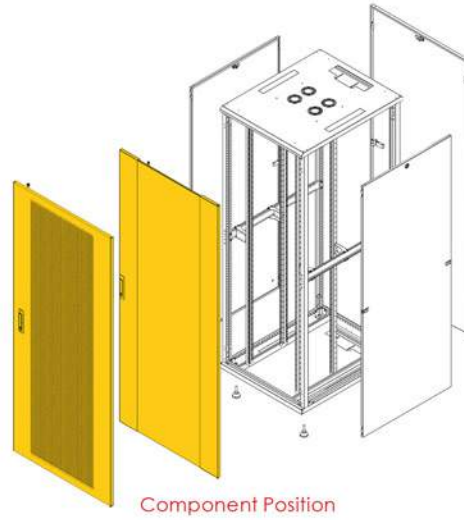
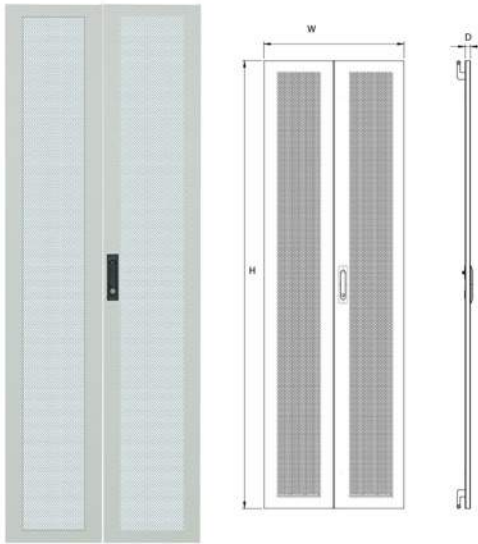

Double Perforated Door Options

Material	1.2 mm Steel	Color	RAL 7035 (Light Grey) and RAL 9005 (Black)		
Finish	Electrostatic Powder Paint		Perforation Rate	65%	
H (U)	W (mm)	D (mm)	H (mm)	Weight kg	Part No
26U	600	22	1194	11,99	CSZ-X-266Y0-0908
36U	600	22	1638	15,70	CSZ-X-366Y0-0908
39U	800	22	1772	21,19	CSZ-X-398Y0-0908
42U	600	22	1905	18,16	CSZ-X-426Y0-0908
42U	800	22	1905	22,83	CSZ-X-428Y0-0908
47U	600	22	2127	20,01	CSZ-X-476Y0-0908
47U	800	22	2127	25,16	CSZ-X-478Y0-0908

High Perforation Rated Double Door

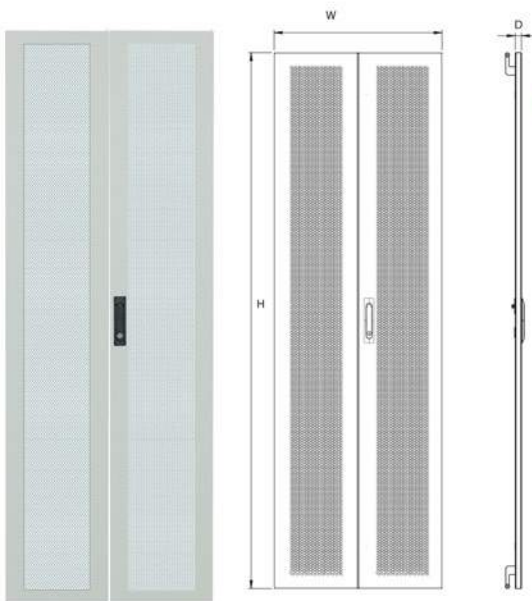

High Perforation Rated Double Door Options

Material	1.2 mm Steel	Color	RAL 7035 (Light Grey) and RAL 9005 (Black)		
Finish	Electrostatic Powder Paint		Perforation Rate	80%	
H (U)	W (mm)	D (mm)	H (mm)	Weight kg	Part No
26U	600	22	1194	11,69	CSZ-X-266Y0-0911
36U	600	22	1638	15,40	CSZ-X-366Y0-0911
39U	800	22	1772	20,89	CSZ-X-398Y0-0911
42U	600	22	1905	17,86	CSZ-X-426Y0-0911
42U	800	22	1905	22,53	CSZ-X-428Y0-0911
47U	600	22	2127	19,71	CSZ-X-476Y0-0911
47U	800	22	2127	24,86	CSZ-X-478Y0-0911

X (Color code): 7:RAL 7035 Light Grey, 9:RAL 9005 Black

Inorax-ST Network Cabinet

Rear Metal Panel with Cable Entry

Material	1 mm Steel	Finish	Electrostatic Powder Paint
Color	RAL 7035 (Light Grey) and RAL 9005 (Black)		

H (U)	W (mm)	D (mm)	H (mm)	Weight kg	Part No
3U	600	23	133	0,97	CSZ-X-036Y0-0915
3U	800	23	133	1,35	CSZ-X-038Y0-0915
4U	600	23	177	1,24	CSZ-X-046Y0-0915
4U	800	23	177	1,71	CSZ-X-048Y0-0915
5U	600	23	222	1,52	CSZ-X-056Y0-0915
5U	800	23	222	2,06	CSZ-X-058Y0-0915
6U	600	23	266	1,79	CSZ-X-066Y0-0915
6U	800	23	266	2,42	CSZ-X-068Y0-0915



Adjustable Cable Entry Panel with EPDM Gasket

Material	1 mm Steel	Finish	Electrostatic Powder Paint
Color	RAL 7035 (Light Grey) and RAL 9005 (Black)		

W (mm)	D (mm)	H (mm)	Weight kg	Part No
350	152	20	0,53	CSZ-X-YYYY0-0803



Adjustable Feet

Material	Steel and Plastic ABS	Finish	Zinc Plated
Packaging	4 pieces in a box		

Maximum Static Load	Set Weight kg	Part No
600 kg / piece	0.35	CCA-0-7014



Castor Set

Material	Steel and Plastic ABS	Finish	Zinc Plated
Packaging	2 pcs with stopper and 2 pcs without stopper in a box		

Maximum Static Load	Set Weight kg	Part No
75 kg / piece	0.77	CCA-0-7015

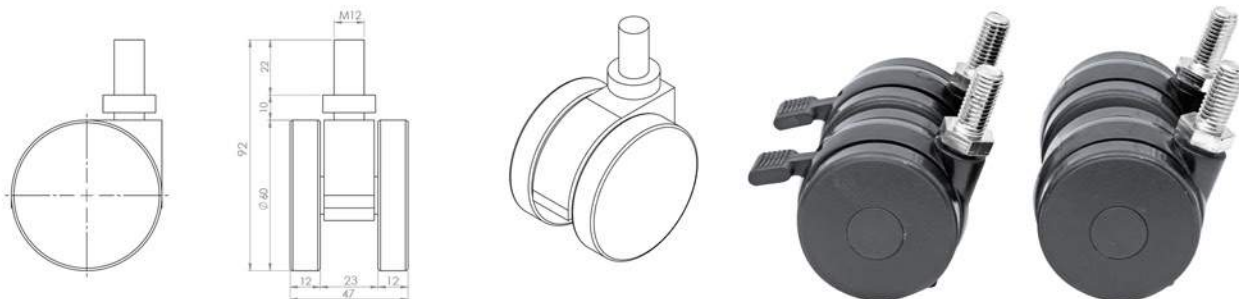

X (Color code): 7:RAL 7035 Light Grey, 9:RAL 9005 Black

Inorax-ST Network Cabinet

Locking Device Systems

Multi Point Lock for Double Doors

Material	Steel, Polyamide
Packaging	1 piece in a box
Part No	CSZ-0-YYYY0-1005

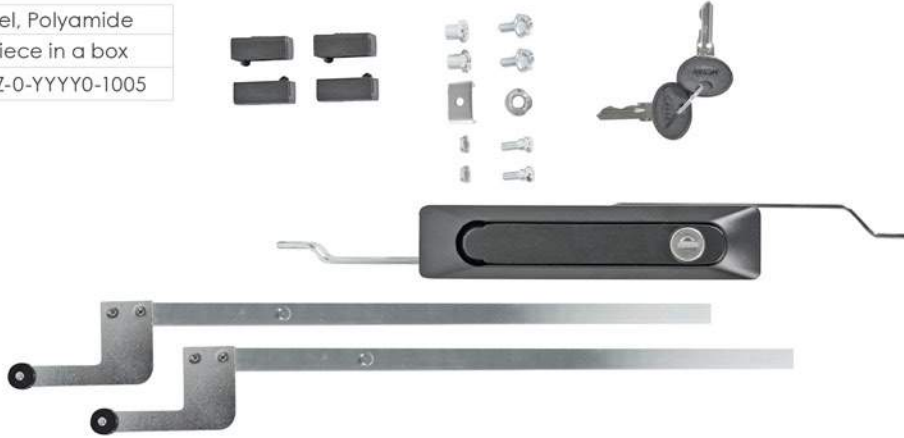

Four Point Lock for Single Curved Perforated Door

Material	Steel, Polyamide
Packaging	1 piece in a box
Part No	CSZ-0-YYYY0-1004



Three Point Lock for Single Perforated Door

Material	Steel, Polyamide
Packaging	1 piece in a box
Part No	CSZ-0-YYYY0-1006



Inorax-ST Network Cabinet



Single Point Lock

Material	Polyamide
Packaging	1 piece in a box
Part No	CPZ-0-YYYY0-1003

Cylindrical Lock for Side Panel



Material	Zamak, Steel
Packaging	1 piece in a box
Part No	CPZ-0-YYYY0-1001

Cylindrical Lock for Rear Metal Solid Panel



Material	Zamak, Steel
Packaging	1 piece in a box
Part No	CPZ-0-YYYY0-1002